

DATV - Up-Converter 70cm/13cm V2

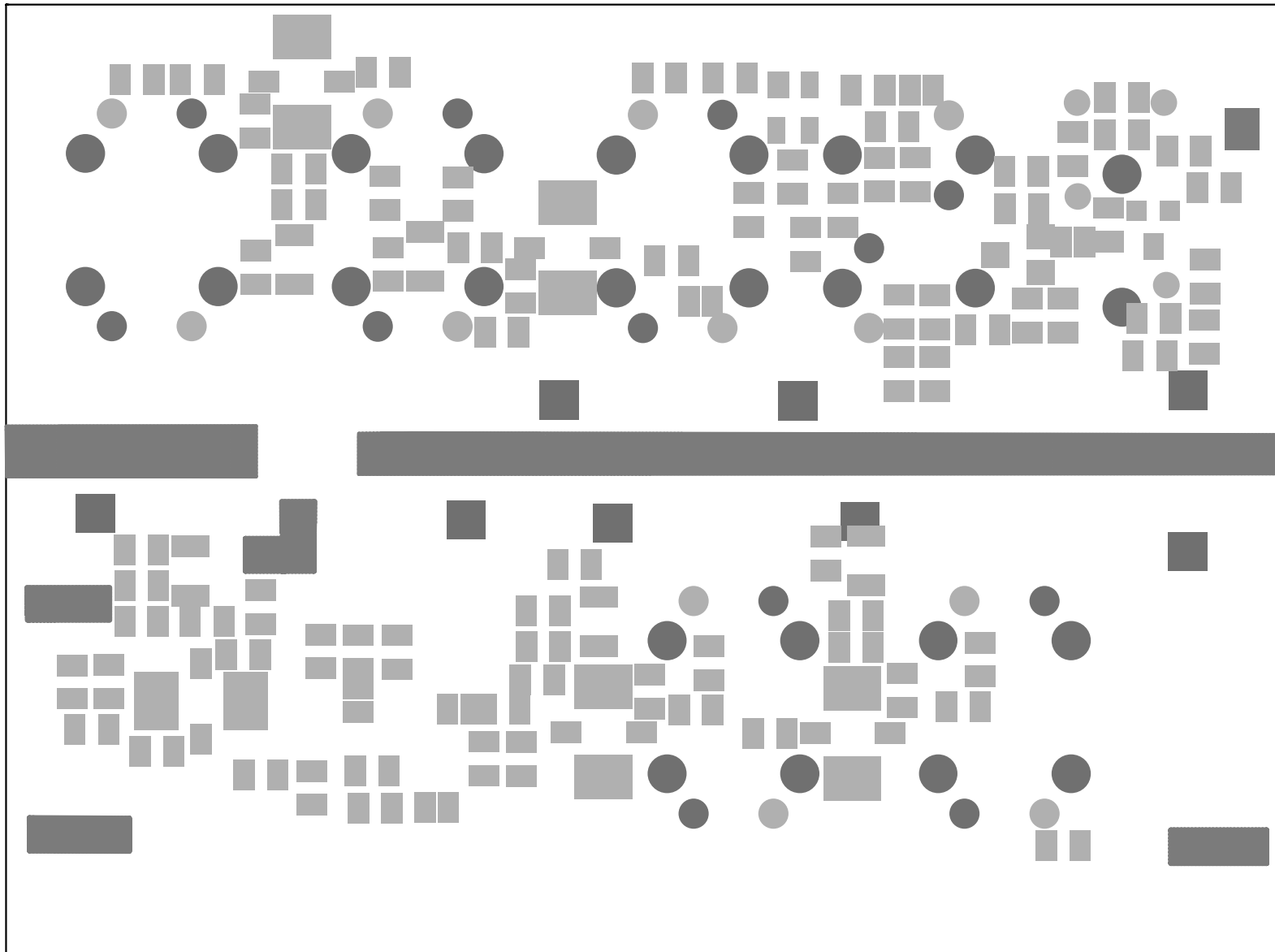

DATV – Up-Converter 70cm/13cm Version 2.0
Bottom Solder Mask

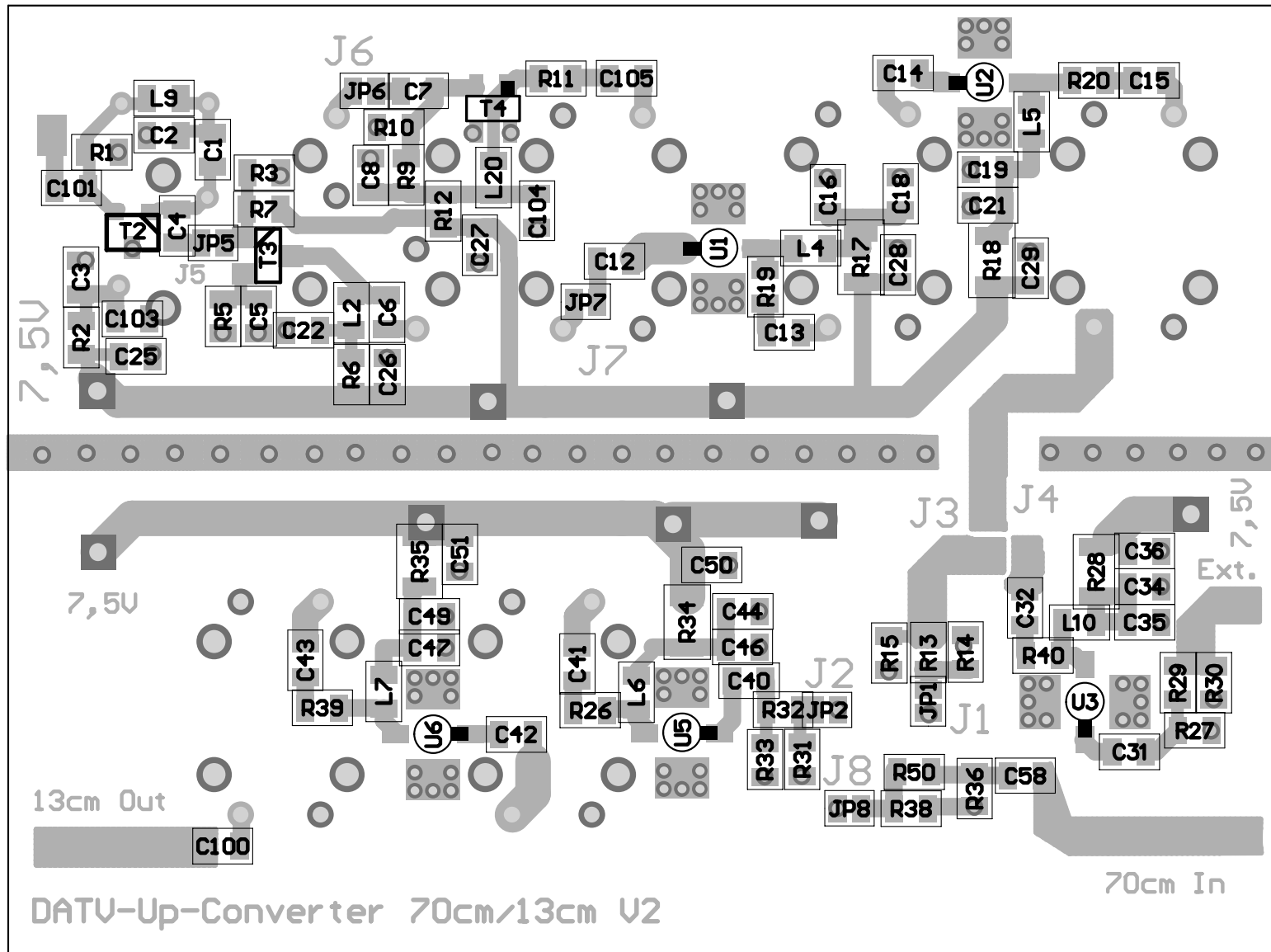

DATV – Up-Converter 70cm/13cm Version 2.0
Bottom Stuffing

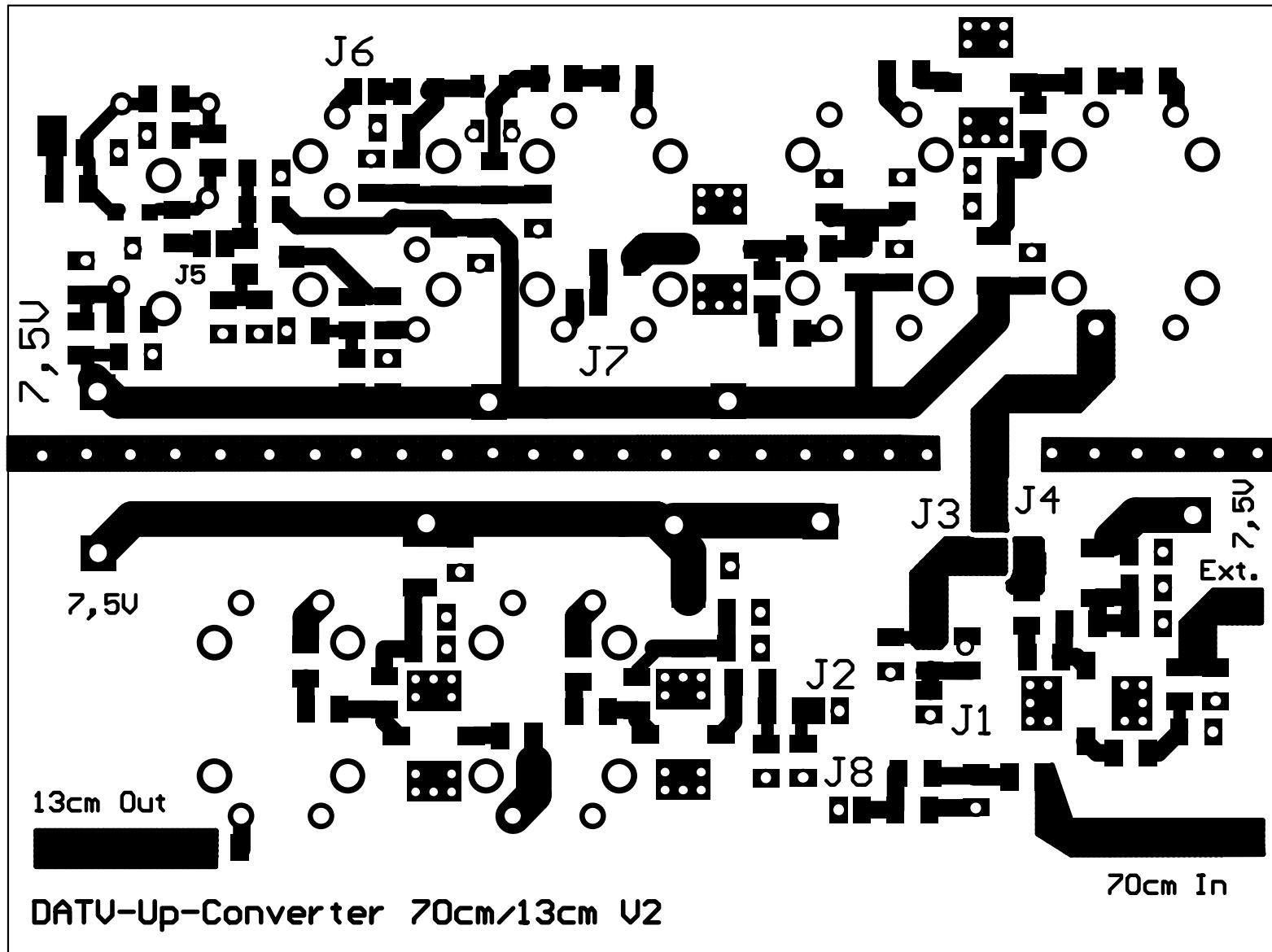

DATV – Up-Converter 70cm/13cm Version 2.0
Bottom Layer

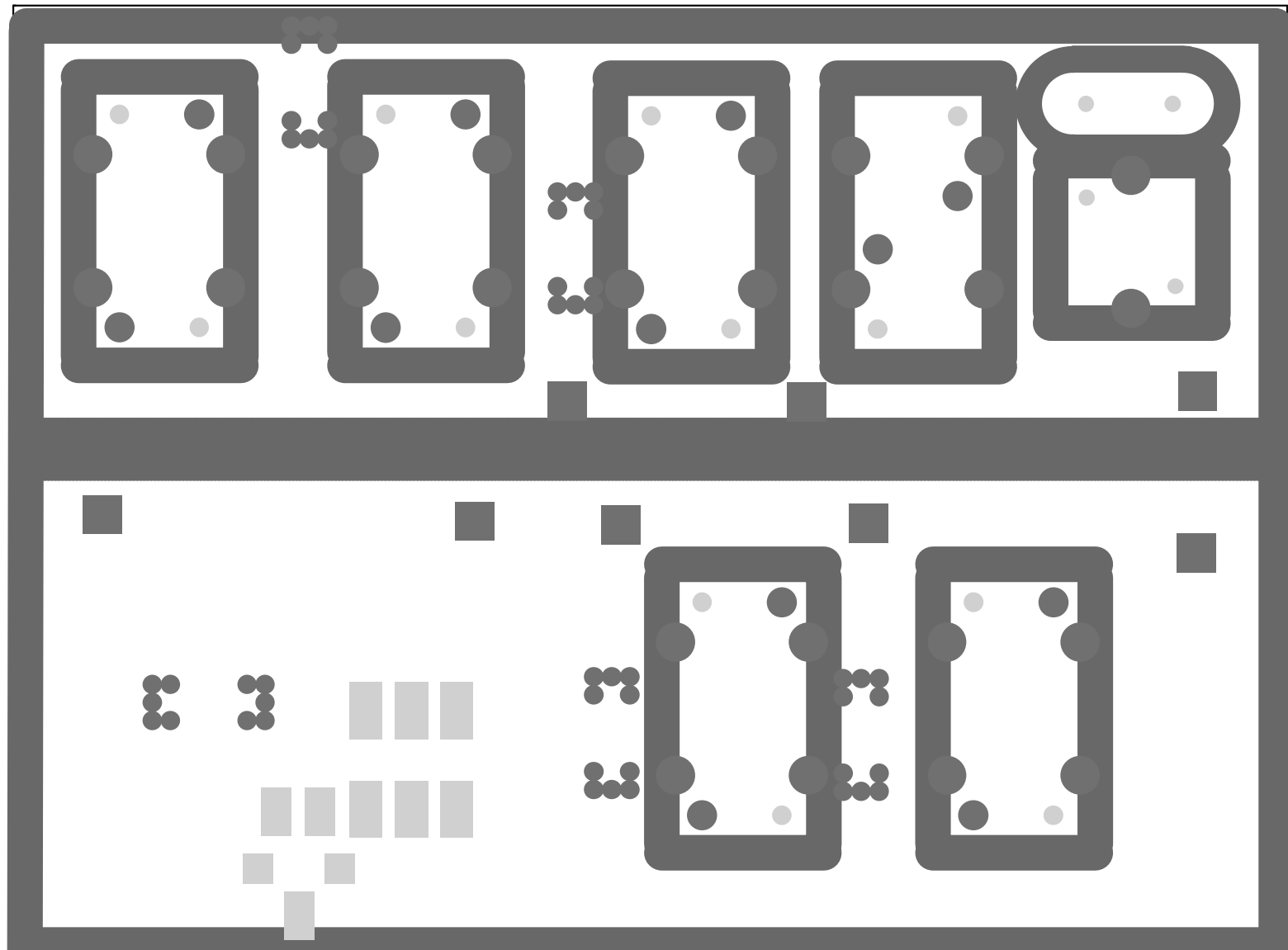

DATV – Up-Converter 70cm/13cm Version 2.0
Top Solder Mask

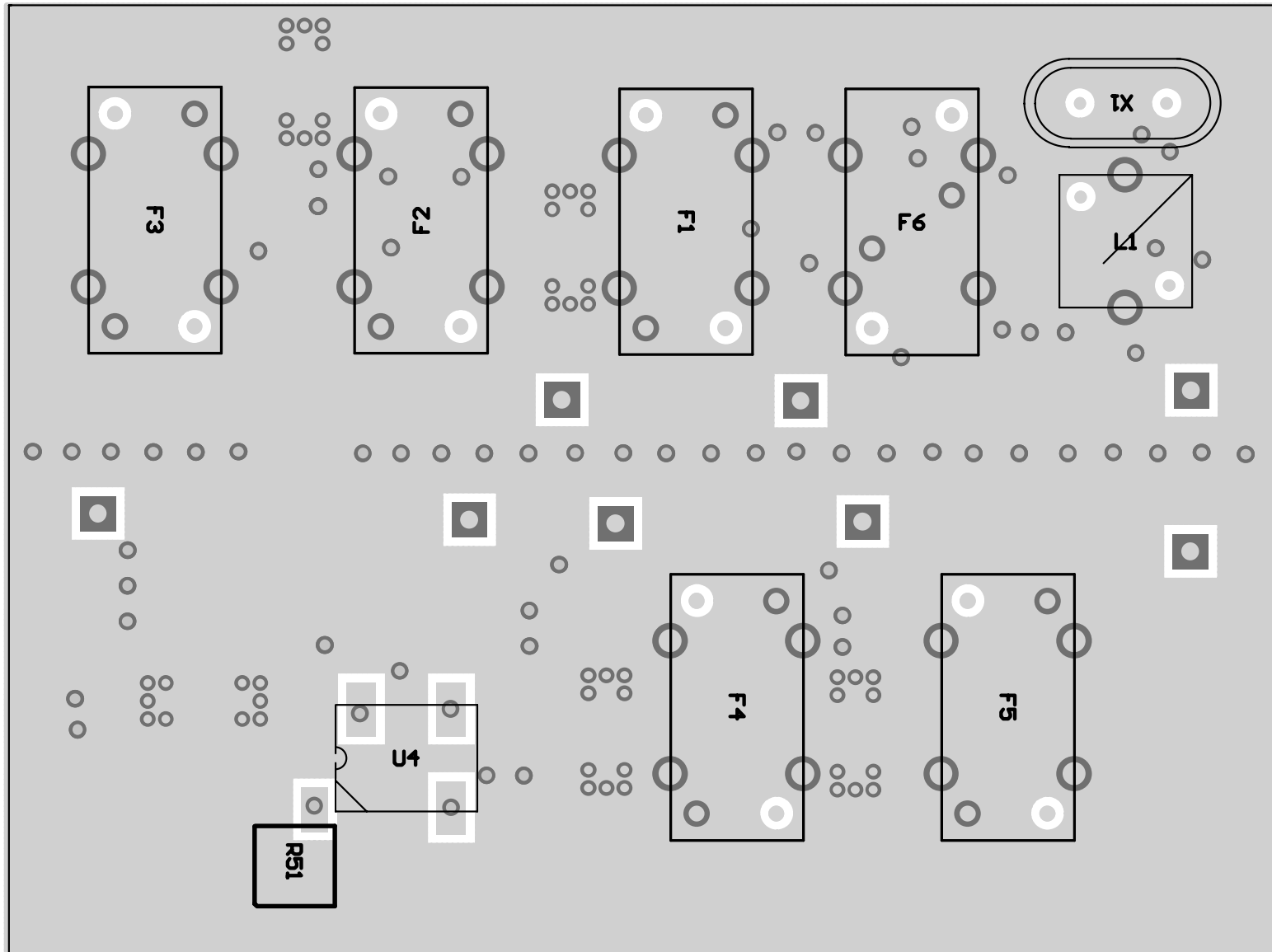

DATV – Up-Converter 70cm/13cm Version 2.0
Top Stuffing

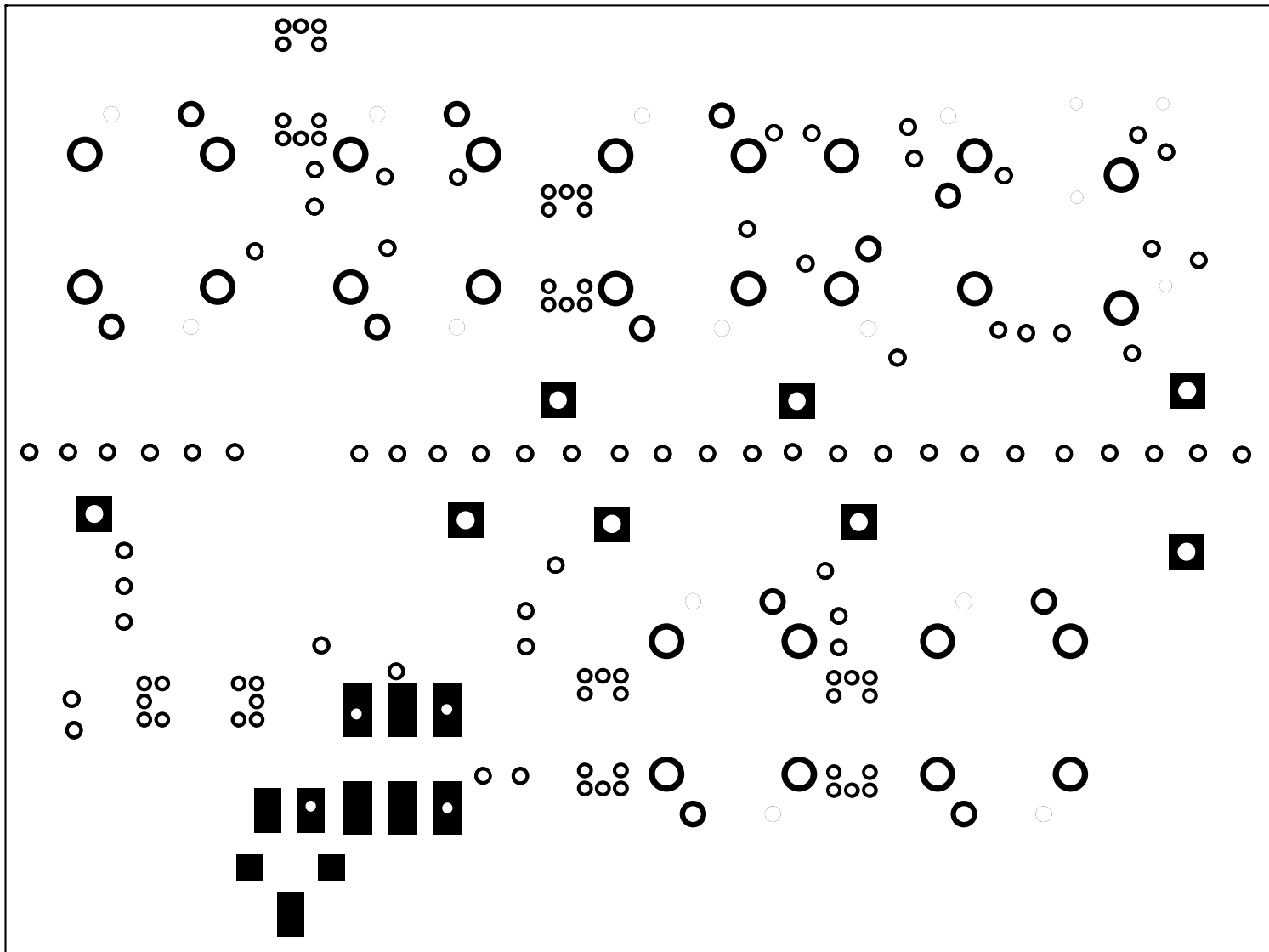

DATV – Up-Converter 70cm/13cm Version 2.0
Top Layer

Designator	Part Type	Footprint	Description	Bezugsquelle
C1	22pF	0805E	Capacitor*	Bürklin
C100	100p	0805E	Capacitor*	Bürklin
C101	1n	0805E	Capacitor*	Bürklin
C103	1n	0805E	Capacitor*	Bürklin
C104	1n	0805E	Capacitor*	Bürklin
C105	2p7	0805E	Capacitor*	Bürklin
C12	82p	0805E	Capacitor*	Bürklin
C13	82pF	0805E	Capacitor*	Bürklin
C14	82pF	0805E	Capacitor*	Bürklin
C15	82pF	0805E	Capacitor*	Bürklin
C16	22pF	0805E	Capacitor*	Bürklin
C18	1nF	0805E	Capacitor*	Bürklin
C19	22pF	0805E	Capacitor*	Bürklin
C2	82pF	0805E	Capacitor*	Bürklin
C21	1nF	0805E	Capacitor*	Bürklin
C22	1nF	0805E	Capacitor*	Bürklin
C25	10nF	0805E	Capacitor*	Bürklin
C26	1nF	0805E	Capacitor*	Bürklin
C27	1nF	0805E	Capacitor*	Bürklin
C28	1nF	0805E	Capacitor*	Bürklin
C29	1nF	0805E	Capacitor*	Bürklin
C3	1nF	0805E	Capacitor*	Bürklin
C31	82pF	0805E	Capacitor*	Bürklin
C32	82pF	0805E	Capacitor*	Bürklin
C34	22pF	0805E	Capacitor*	Bürklin
C35	1nF	0805E	Capacitor*	Bürklin
C36	1nF	0805E	Capacitor*	Bürklin
C4	1pF	0805E	Capacitor*	Bürklin
C40	82pF	0805E	Capacitor*	Bürklin
C41	82pF	0805E	Capacitor*	Bürklin
C42	82pF	0805E	Capacitor*	Bürklin
C43	82pF	0805E	Capacitor*	Bürklin
C44	22pF	0805E	Capacitor*	Bürklin
C46	1nF	0805E	Capacitor*	Bürklin
C47	22pF	0805E	Capacitor*	Bürklin
C49	1nF	0805E	Capacitor*	Bürklin
C5	68pF	0805E	Capacitor*	Bürklin
C50	1nF	0805E	Capacitor*	Bürklin
C51	1nF	0805E	Capacitor*	Bürklin
C58	100pF	0805E	Capacitor*	Bürklin
C6	4p7	0805E	Capacitor*	Bürklin
C7	8p2	0805E	Capacitor*	Bürklin
C8	1nF	0805E	Capacitor*	Bürklin
F1	NEOSID-7.2G 980	NEOSID-7.2G	Helical F.	Neosid

F2	NEOSID-7.2G 2000	NEOSID-7.2G	Helical F.	Neosid
F3	NEOSID-7.2G 2000	NEOSID-7.2G	Helical F.	Neosid
F4	NEOSID-7.2G-2450	NEOSID-7.2G	Helical F.	Neosid
F5	NEOSID-7.2G-2450	NEOSID-7.2G	Helical F.	Neosid
F6	NEOSID-7.2 E/C 315	NEOSID-7.2 E/C **	Helical F.	Neosid
JP2	0R	SMD-MP	0-Ohm Resistor	
JP5	0R	SMD-MP	0-Ohm Resistor	
JP6	0R	SMD-MP	0-Ohm Resistor	
JP7	0R	SMD-MP	0-Ohm Resistor	
JP8	0R	SMD-MP	0-Ohm Resistor	
L1	6,5W(Ferrit)	NEOSID7.1	var.Inductor	Neosid
L10	22nH	0805E	Inductor	Würth
L2	56nH	0805E	Inductor	Würth
L20	68n	0805E	Inductor	Würth
L4	22nH	0805E	Inductor	Würth
L5	22nH	0805E	Inductor	Würth
L6	18n	0805E	Inductor	Würth
L7	18n	0805E	Inductor	Würth
L9	330nH	0805E	Inductor	Würth
R1	220R	0805E	Resistor**	Bürklin
R10	2k7	0805E	Resistor**	Bürklin
R11	1R	0805E	Resistor**	Bürklin
R12	100R	0805E	Resistor**	Bürklin
R13	12R	0805E	Resistor**	Bürklin
R14	430R	0805E	Resistor**	Bürklin
R15	430R	0805E	Resistor**	Bürklin
R17	39R	1206E	Resistor**	Bürklin
R18	39R	1206E	Resistor**	Bürklin
R19	1R	0805E	Resistor**	Bürklin
R2	100R	0805E	Resistor**	Bürklin
R20	1R	0805E	Resistor**	Bürklin
R26	1R	0805E	Resistor**	Bürklin
R27	180R	0805E	Resistor**	Bürklin
R28	39R	1206E	Resistor**	Bürklin
R29	30R	0805E	Resistor**	Bürklin
R3	2k7	0805E	Resistor**	Bürklin
R30	180R	0805E	Resistor**	Bürklin
R31	300R	0805E	Resistor**	Bürklin
R32	18R	0805E	Resistor**	Bürklin
R33	300R	0805E	Resistor**	Bürklin
R34	39R	1206E	Resistor**	Bürklin
R35	39R	1206E	Resistor**	Bürklin
R36	51R	0805E	Resistor**	Bürklin

R38	51R	0805E	Resistor**	Bürklin
R39	1R	0805E	Resistor**	Bürklin
R40	1R	0805E	Resistor**	Bürklin
R5	150R	0805E	Resistor**	Bürklin
R50	330R	0805E	Resistor**	Bürklin
R51	100R	POTI	Resistor**	Bürklin
R6	100R	0805E	Resistor**	Bürklin
R7	27k	0805E	Resistor**	Bürklin
R9	27k	0805E	Resistor**	Bürklin
T2	J310	SOT-23-3	FET	Eisch-Kafka
T3	BFR92A	SOT23Z	NPN Transistor	Eisch-Kafka
T4	BFG93A	SOT-143	NPN Transistor	Eisch-Kafka
U1	SGA 6486	SGA	Amplifier	ACAL
U2	SGA 6486	SGA	Amplifier	ACAL
U3	SGA 6486	SGA	Amplifier	ACAL
U4	ADE-28	CD542	Mixer	Municom
U5	SGA 6486	SGA	Amplifier	ACAL
U6	SGA 6486	SGA	Amplifier	ACAL
X1	107,611MHz	HC-49/U	Crystal	Quarztechnik
	Weißblechgehäuse (55,5x74)cm			Eisch-Kafka

* SMD Keramik-Vielschichtkondensatoren Reihe COG

** SMD Metallschichtwiderstände

Adressen

ACAL GmbH
Fischeräcker 2
74220 Flein/Heilbronn

Würth Electronic
Max- Eyth-Str. 1
74638 Waldenburg

Municom
Nibelungenstr. 304
64625 Bensheim

Quarz Technik
Postfach 1205
54543 Daun

Neosid
Postfach 1354
58543 Halver

Eisch-Kafka-Electronic
Abt-Ulrich-Str. 16
89079 Ulm-Goggelingen